

Precision Stainless Steel Three Jaw Chuck – Square

Model: BTDSQ12– Capacity 1” to 2”

PATENTED

This three-jaw chuck is a very precise work holding device. The included torque wrench is preset. The wrench will click thru when the preset limit has been reached. This will insure constant force on the work piece. Not using this wrench will result in less accurate work holding.

The outer sides are not ground central to the zero of this fixture. Included are three precision setup bushings. Use the setup bushing closest to your part diameter to accurately find the center point. The chuck is built with three plates, when locating, only tap on the plate adjacent to mounting surface.

There are six thru holes (10-32 screw) for mounting to an adapter plate. The pattern is equally spaced on a 4.5” diameter. On three sides there are two ¼-20 tapped holes on 3.50” spacing.

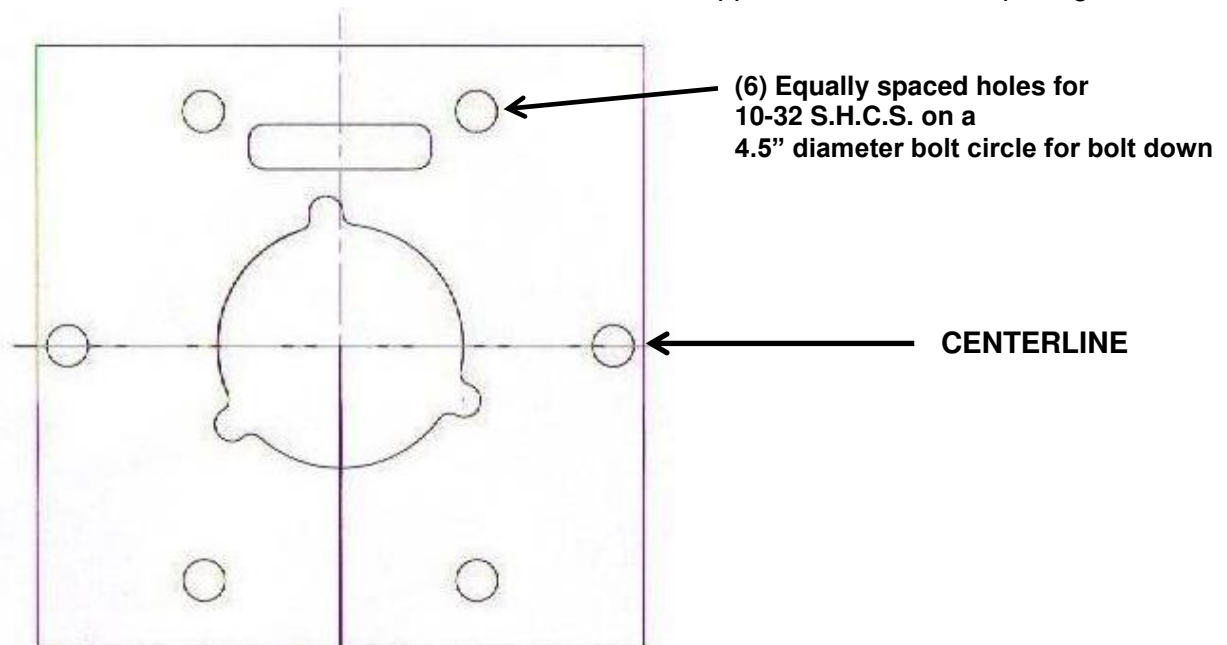

Contact Pin Replacement - Use only Hermann Schmidt replacement contact pins.

- Put the chuck face down on risers.
- Using a small diameter punch remove shorter contact pin by tapping pin into relief cut in jaws.
- Tap longer portion of contact pin down through front of chuck.
- Cut new contact pin to proper length and debur ends. The long portion installs through the front of chuck and small through the back of chuck.

Installation service is available.

Hermann Schmidt® Tools are Made in the USA.